

Clima-Pave™

Permeable Paving Solutions





Carrickmacross Civic Offices & Library, Co. Monaghan

contents

1. Sustainable Urban Drainage Systems (SUDS) and Water Source Control

Advantages of Permeable Paving 03

Advantage of Clima-Pave™ for your project 04

2. Clima-Pave™ Product Range

Slane 06

Lismore 08

Mellifont 09

Newgrange 10

Boyne 11

Killeen 12

Belvedere 13

3. Clima-Pave™ Technical Information

Design Guidance 16-17

Permeable Paving Aggregates 18

Materials for HGV Trafficked Areas 19

Typical Design Diagrams 20-22

Construction & Maintenance Guidelines 23

Terms & Conditions 24

The rapid development of previously green-field sites and the associated creation of impermeable areas such as roofs, car parks and footpaths will mean that at project conception stage there will be potentially large volumes of surface water to be dealt with. Traditionally this has been done by piping the surface water into storage tanks or discharging it into nearby streams or surface water drainage. This method of drainage is not currently favoured by planners and designers, as it simply moves the surface water downstream where it still has to be dealt with. This is especially important where large volumes of water need to be dealt with during heavy rainfall events. Piping large volumes of water into streams and rivers increases the risk of flooding and also allows for the potential pollution of local water courses and drinking water supplies.

Sustainable Urban Drainage Systems (SUDS) and Water Source Control

Planners are encouraging the use of Sustainable Urban Drainage Systems (SUDS) in all new developments, in particular the use of appropriate source control techniques is important as this allows for the containment of the surface water collected on the site and for this surface water to be dealt with on-site as opposed to traditionally draining it off-site. SUDS, as a sustainable development approach to Surface Water Design Techniques, has the aim of balancing the following:

- 1. To manage water run-off from developed areas to similar quantities prior to development (Source Control)**
- 2. Reduce and avoid incidences of downstream flooding**
- 3. To protect or enhance water quality of the run-off**
- 4. To improve or enhance the amenity where possible**

➤ Advantages of Permeable Paving

- Permeable Paving is a 'source control' method. Water is managed and dealt with on-site without piping off to storage tanks or surface water treatment systems
- The Water Framework Directive (Directive 2000/60/EC) requires that surface water discharges are managed to ensure that risk of contamination or pollution are mitigated. Permeable paving systems filter contaminants by microbial action. There is no requirement for additional filtering/polishing with Permeable Paving in normal use
- Separate attenuation tank systems are not required
- No need for gullies or channels or conventional drainage
- Recharges ground water
- Roofs, roads and other non-permeable areas can be discharged into permeable paving (No gullies required)
- No ponding or surface water
- Collected water can potentially be re-used for non-potable purposes
- Improves water quality



Clima-Pave™, the permeable paving solution from Kilsaran, offers an advantage over traditional SUDS techniques, such as storm water attenuation tanks. This is because the stone based sub-base, which needs to be installed for any type of surfacing material, is adapted to an open graded material in permeable paving systems. This allows the water collected from the site to be stored in the pavement and either infiltrated back into the ground or discharged at a controlled rate into the surface water drainage system.

The Clima-Pave™ system is constructed using our specially engineered permeable paving block, which has enlarged joints on all sides, typically 4-8mm in width. When the blocks have been laid, a corresponding slot is formed between the paving blocks which are then filled with a clean 3mm aggregate. This allows water to rapidly drain from the surface down into the pavement.

Traditional block paving is laid on a sand bedding layer and a Type 1/CL. 804 sub-base. To allow for storage and infiltration of the surface water percolating through the block, permeable block paving is laid on a grit laying course instead of sand and an open-graded stone sub-base instead of Type 1/CL. 804.

Clima-Pave™ Permeable Paving Solutions



➤ Advantages of Clima-Pave™ for your project

Clima-Pave™ from Kilsaran offers the widest range of permeable paving products for use in commercial, retail and civic projects.

Kilsaran can also offer a full site-specific permeable paving design for your project, taking into account the site ground conditions, drainage requirements and structural and traffic loading requirements for the site. This is a chargeable service and Kilsaran will provide an indemnified design provided by our nominated Consulting Engineer who will visit the site if required to appraise the installation.

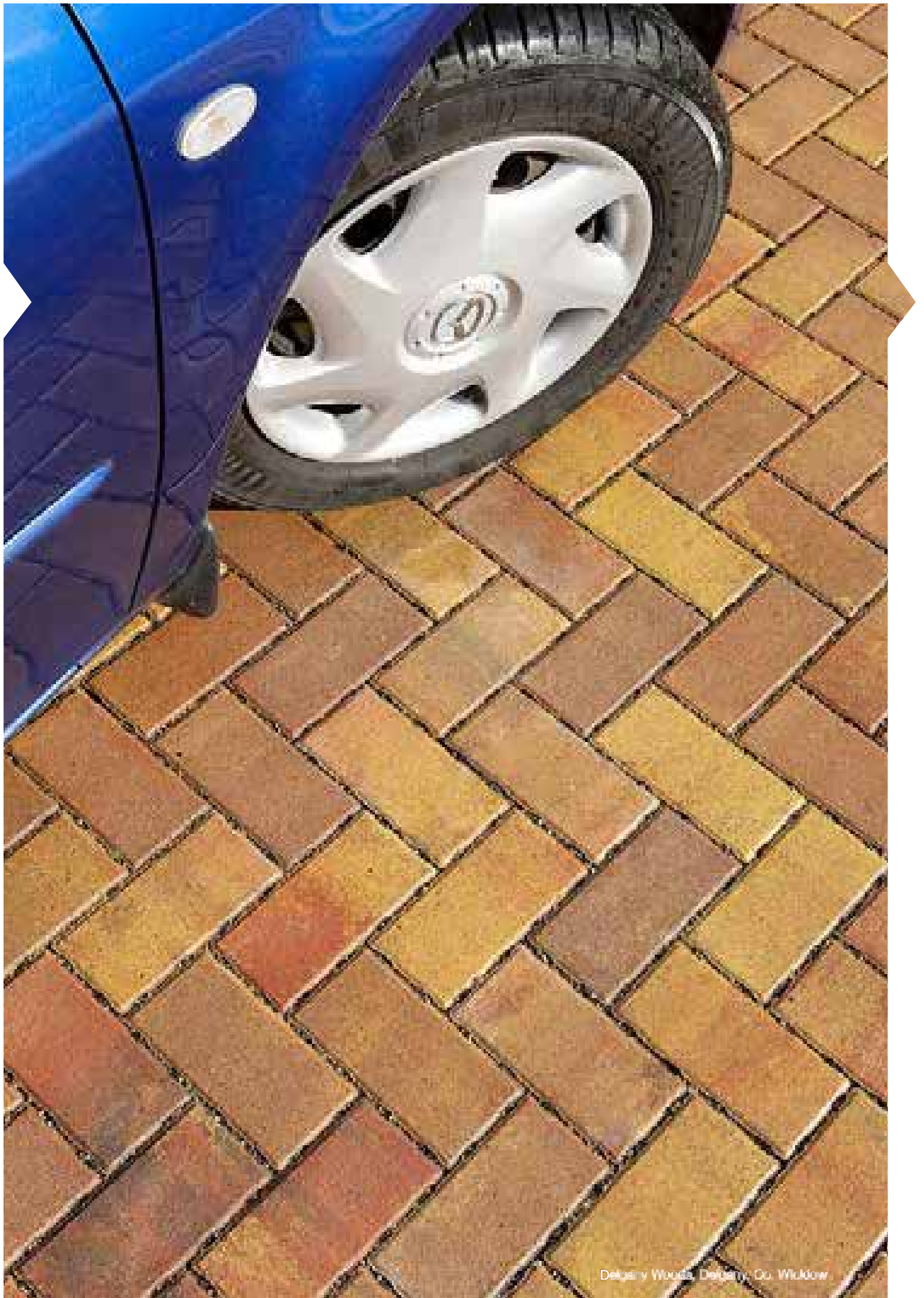

Clima-Pave™ Product Range

- Slane
- Lismore
- Mellifont
- Newgrange
- Boyne
- Killeen Flags
- Belvedere Flags

➤ Benefits

- Unique spacer design maximises drainage whilst maintaining a smaller finished joint, paved area safer for heels etc. and easier to maintain
- Traditional 200 x 100 size unit
- Suitable for laying in stretcher course and herringbone pattern for heavier use
- Machine lay option available

➤ Technical & Performance Data

Sizes	200 x 100 x 60mm, 200 x 100 x 80mm, 240 x 160 x 80mm
Manufacturing Standard	BS EN 1338:2003
Manufacturing Method	Hydraulically pressed semi-dry concrete
Constituents	Aggregates, cement, admixture and colour pigment
Strength	Typical Tensile Splitting Strength of ≥ 3.6 MPa and a failure load of ≥ 250 N/mm
Permeability	1800 litres / second / hectare
Finish	Standard
Applications	Domestic, Civic, Commercial and Heavy Industrial

➤ Dimensions & Profile

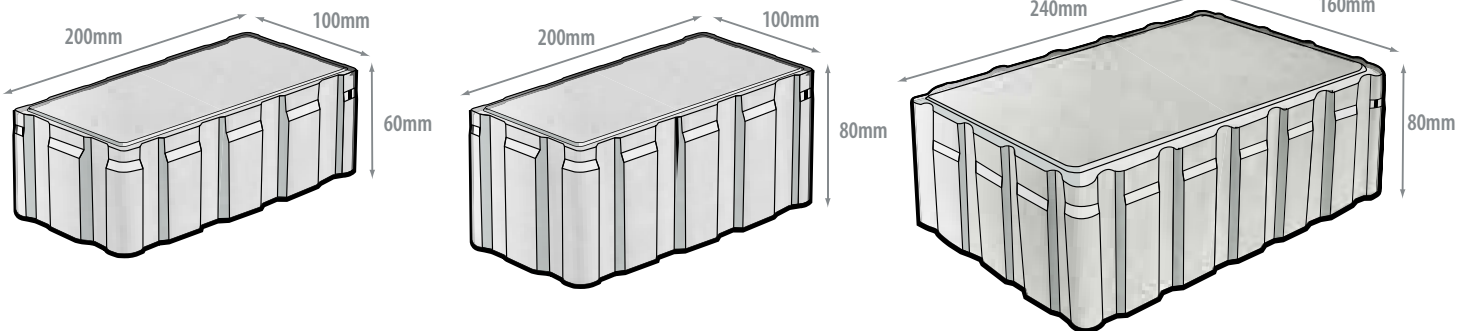

➤ Colours Available

Block Size: 200mm x 100mm x 80mm/60mm

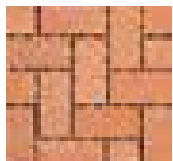

➤ Terracotta

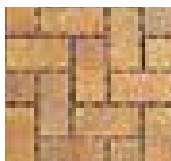

➤ Rustic

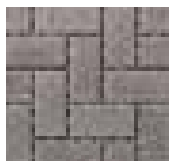

➤ Raven

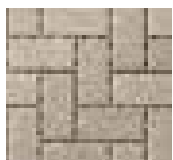

➤ Natural



➤ Multi



➤ Curragh Gold

Block Size: 240mm x 160mm x 80mm

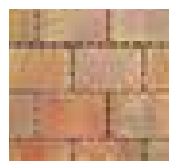

➤ Rustic

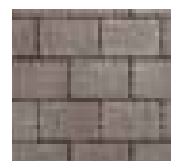

➤ Raven

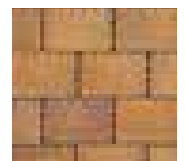

➤ Curragh Gold



Phibblestown School and Community Centre, Dublin 15

› Recent Projects

Project & Location	Main Contractor	Quantity (m ²)
Tesco, Rush, Co. Dublin	Precision Construction Ltd.	5,000
Tesco, Naas, Co. Kildare	Precision Construction Ltd.	12,000
Dobbies Garden World, Speke, Liverpool, UK	Gilbert Ash (NI) Ltd.	1,800
Edinburgh Royal Infirmary, Edinburgh, UK	Balfour Beatty Civil Engineering Ltd.	12,000
Phibblestown School and Community Centre, Dublin 15	PJ Hegarty Ltd./Shannon Valley	3,000
BMW Dealership Cambourne, Cambridgeshire, UK	Sustainable Drainage Systems Ltd / SDC Builders	2,500
Beaumont Hospital, Dublin 9	Bretland Construction/Sisk	3,500

➤ Benefits

- Clean, sharp edges
- No chamfer: Ideal for areas where trolleys are used
- 3-size mix
- Available in a range of colours

➤ Technical & Performance Data

Sizes	Single Size: 240 x 160 x 80mm 3 Size Mix: 240 x 160 x 80mm, 160 x 160 x 80mm, 120 x 160 x 80mm The 3 size mix comes in a 60mm depth also
Manufacturing Standard	BS EN 1338:2003
Manufacturing Method	Hydraulically pressed semi-dry concrete
Constituents	Aggregates, sand, admixtures, cement and colour pigments
Strength	Typical Tensile Splitting Strength of ≥ 3.6 MPa and a failure load of ≥ 250 N/mm
Permeability	1800 litres / second / hectare
Finish	Standard
Applications	Domestic, Civic and Commercial

➤ Dimensions & Profile

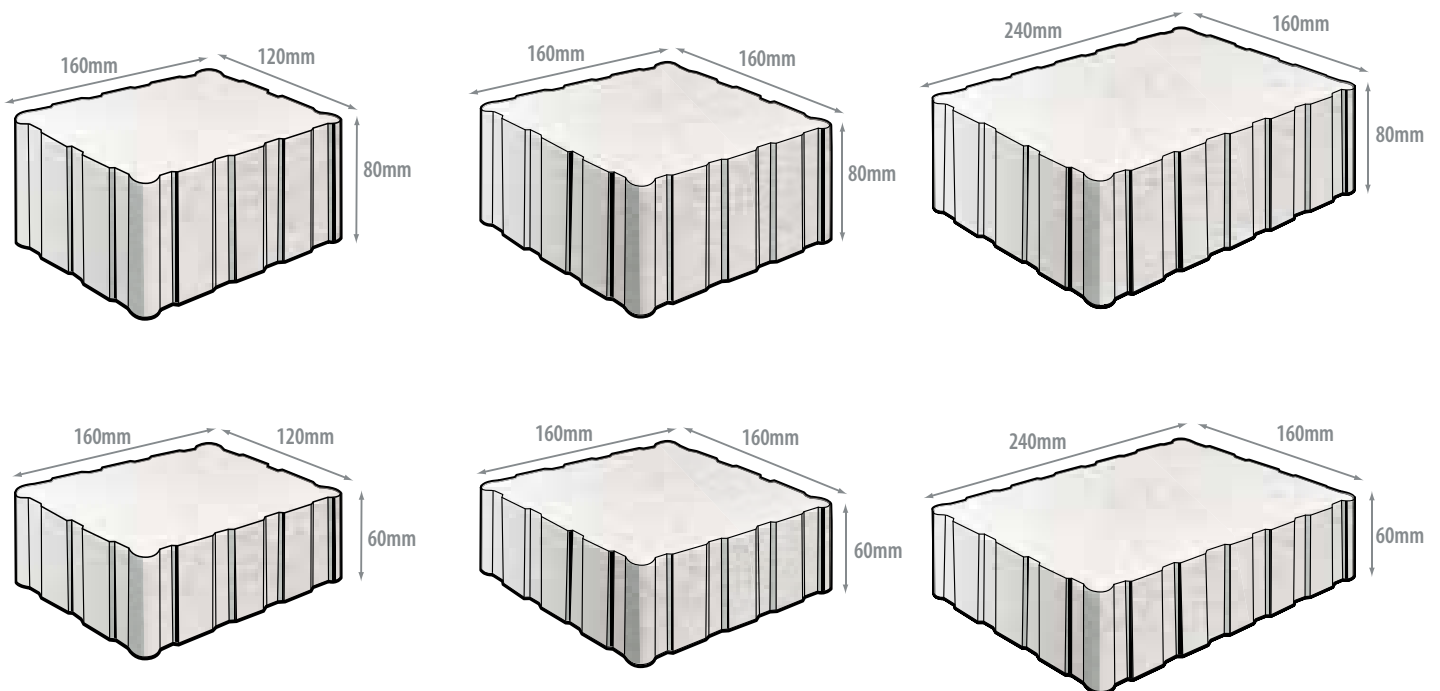

➤ Colours Available

Block Sizes: Single Size: 240 x 160 x 80mm. 3 Size Mix: 240 x 160 x 80mm/60mm, 160 x 160 x 80mm/60mm, 120 x 160 x 80mm/60mm



➤ Natural



➤ Raven

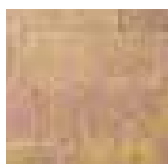

➤ Rustic

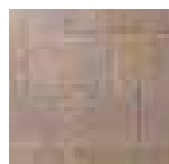

➤ Curragh Gold

> Benefits

- Antiqued finish gives the look of time-worn cobble
- 3-size mix
- Available in a range of colours

> Technical & Performance Data

Sizes	3 Size Mix: 240 x 160 x 80mm, 160 x 160 x 80mm, 120 x 160 x 80mm The 3 size mix comes in a 60mm depth also
Manufacturing Standard	BS EN 1338:2003
Manufacturing Method	Hydraulically pressed semi-dry concrete
Constituents	Aggregates, sand, admixtures, cement and colour pigments
Strength	Typical Tensile Splitting Strength of ≥ 3.6 MPa and a failure load of ≥ 250 N/mm
Permeability	1800 litres / second / hectare
Finish	Antiqued (time worn/aged finish)
Applications	Domestic, Civic and Commercial

> Dimensions & Profile

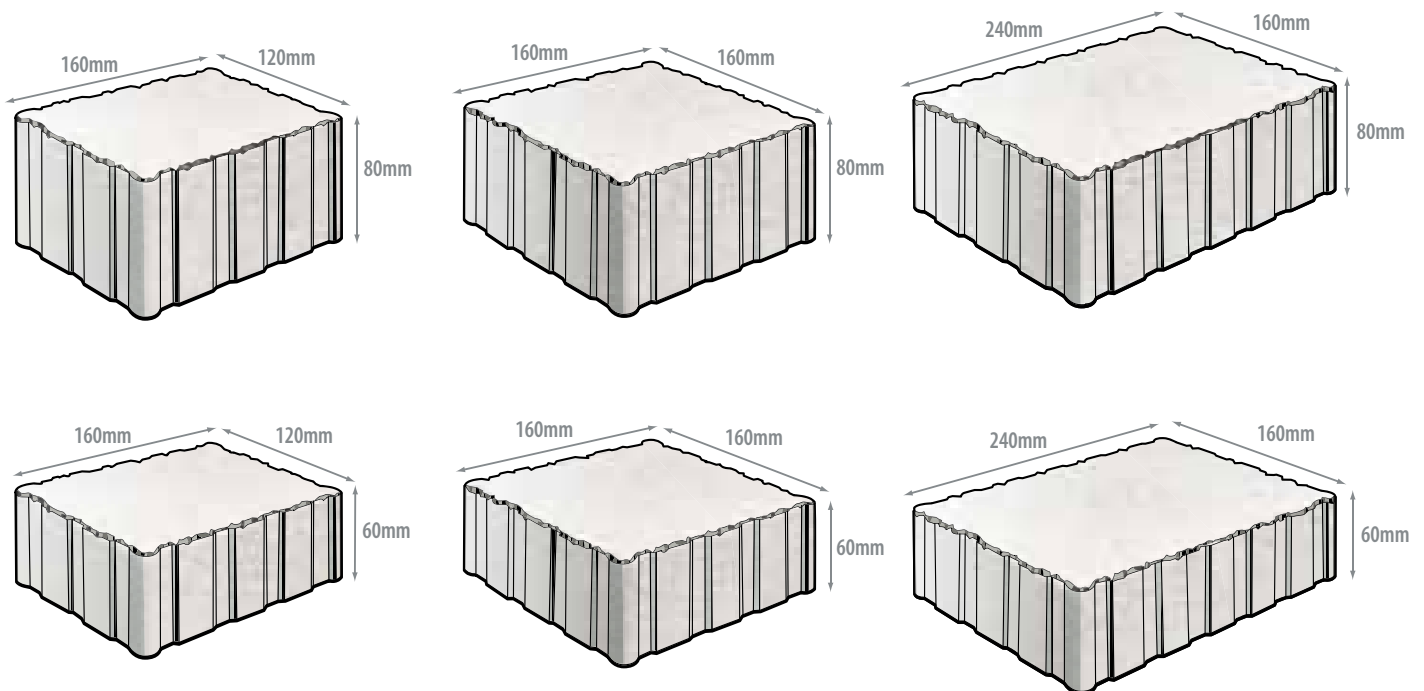

Block Sizes: 3 Size Mix: 240 x 160 x 80mm/60mm, 160 x 160 x 80mm/60mm, 120 x 160 x 80mm/60mm



> Natural



> Raven



> Rustic



> Curragh Gold

➤ Benefits

- Textured granite-effect finish
- 3-size mix
- Available in a range of colours

➤ Technical & Performance Data

Sizes	3 Size Mix: 240 x 160 x 80mm, 160 x 160 x 80mm, 120 x 160 x 80mm The 3 size mix comes in a 60mm depth also
Manufacturing Standard	BS EN 1338:2003
Manufacturing Method	Hydraulically pressed semi-dry concrete
Constituents	Aggregates, sand, admixtures, cement and colour pigments
Strength	Typical Tensile Splitting Strength of ≥ 3.6 MPa and a failure load of ≥ 250 N/mm
Permeability	1800 litres / second / hectare
Finish	Shot-Blasted (fine textured finish)
Applications	Domestic, Civic and Commercial

➤ Dimensions & Profile

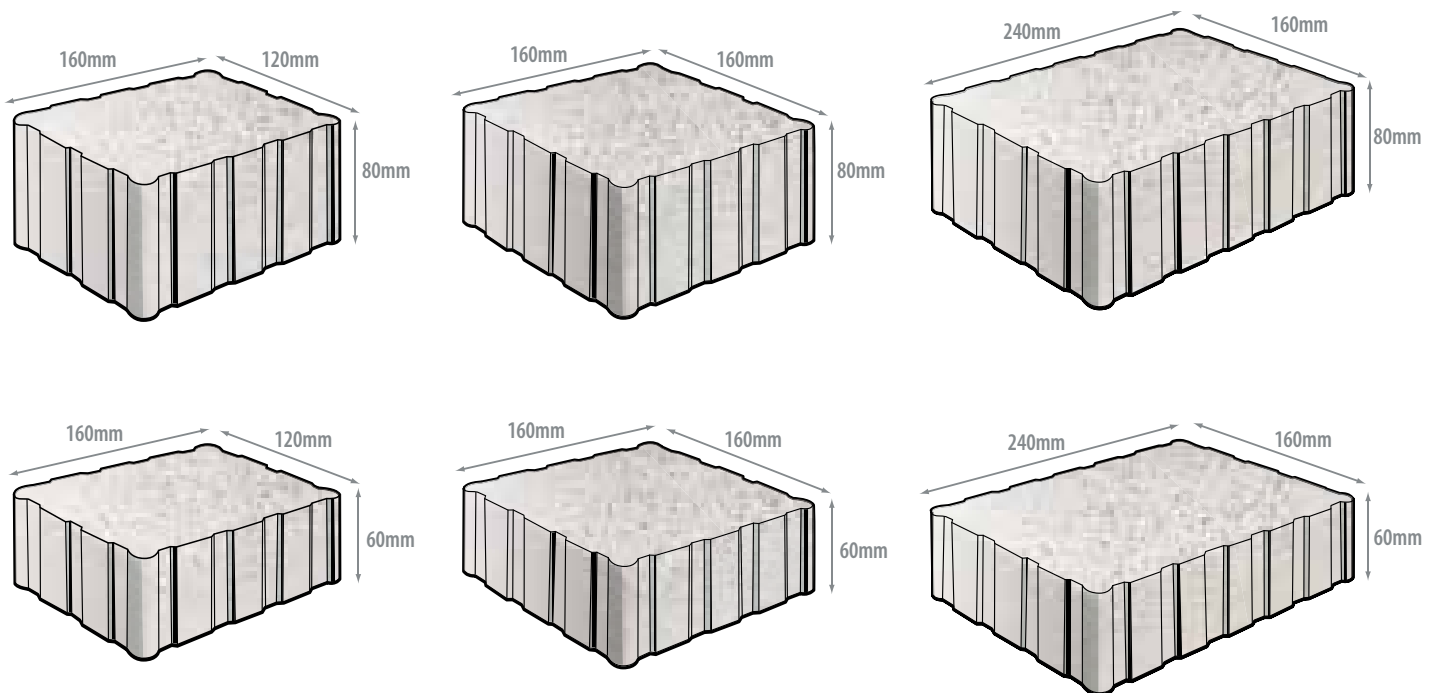

➤ Colours Available

Block Sizes: 3 Size Mix: 240 x 160 x 80mm/60mm, 160 x 160 x 80mm/60mm, 120 x 160 x 80mm/60mm



➤ Silver Granite

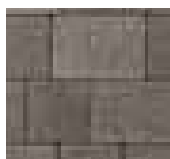

➤ Black Granite



➤ Yellow Granite

➤ Benefits

- Cobble-effect paving stone
- Embossed finish
- Larger spacer unit

➤ Technical & Performance Data

Sizes	192 x 132 x 60mm, 157 x 132 x 60mm
Manufacturing Standard	BS EN 1338:2003
Manufacturing Method	Hydraulically pressed semi-dry concrete
Constituents	Aggregates, sand, admixtures, cement and colour pigments
Strength	Typical Tensile Splitting Strength of ≥ 3.6 MPa and a failure load of ≥ 250 N/mm
Permeability	1800 litres / second / hectare
Finish	Embossed
Applications	Domestic, Civic and Commercial

➤ Dimensions & Profile

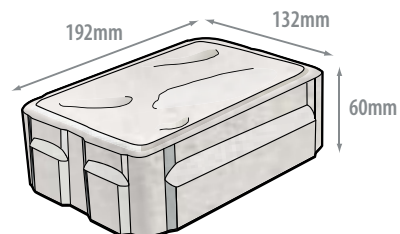
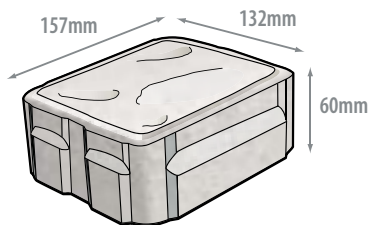

➤ Colours Available

Block Sizes: 192 x 132 x 60mm, 157 x 132 x 60mm



➤ Natural

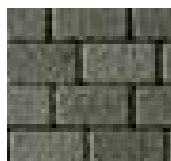

➤ Raven



➤ Rustic

➤ Benefits

- Sharp edge
- 4 co-ordinating sizes
- Granite-effect finish available
- 70mm depth

➤ Technical & Performance Data

Sizes	4 size mix: 490 x 260 x 70mm, 410 x 260 x 70mm, 390 x 260 x 70mm, 340 x 260 x 70mm
Manufacturing Standard	BS EN 1339:2003
Manufacturing Method	Hydraulically pressed semi-dry concrete
Constituents	Aggregates, sand, admixtures, cement and colour pigments
Permeability	1800 litres / second / hectare
Finish	Ground or Antiqued finish
Applications	Domestic, Civic and Commercial

➤ Dimensions & Profile

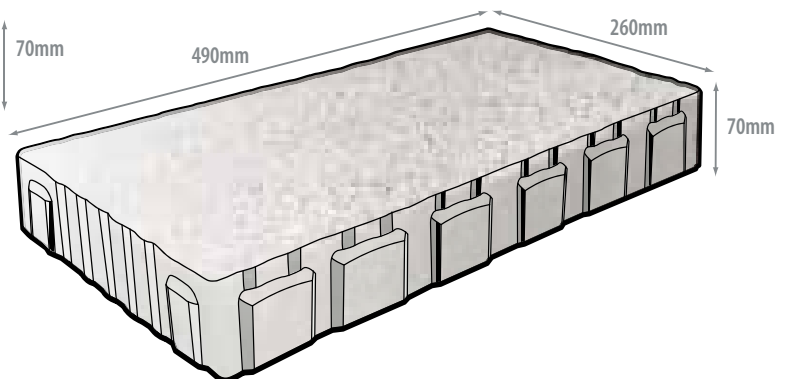
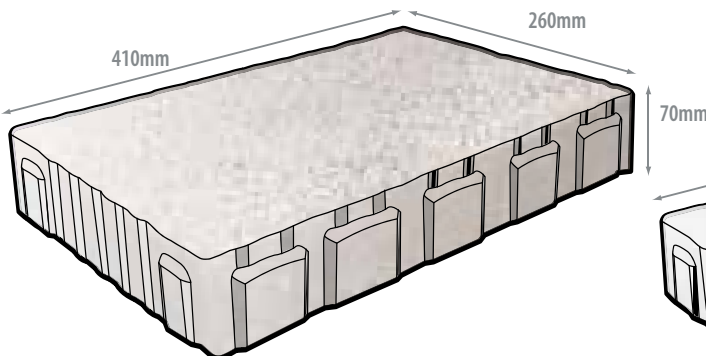
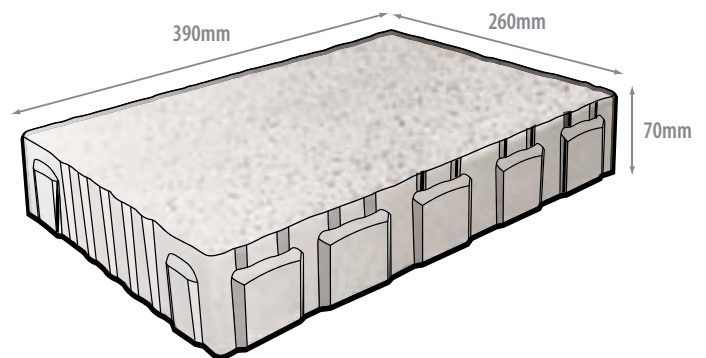
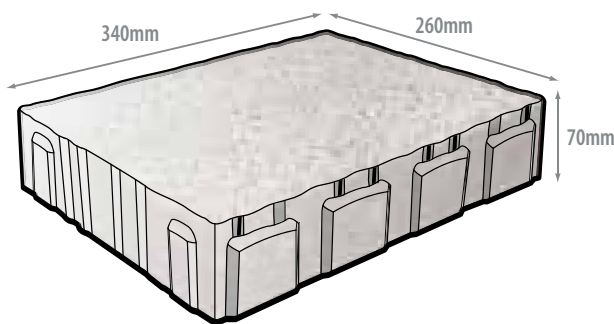

➤ Colours Available

Block Sizes: 4 size mix: 490 x 260 x 70mm, 410 x 260 x 70mm, 390 x 260 x 70mm, 340 x 260 x 70mm



➤ Black Granite



➤ Silver Granite



➤ Autumn Harvest

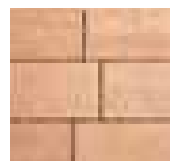

➤ Sunset Red

> Benefits

- Embossed finish
- 4 co-ordinating sizes
- Random pattern
- 60mm depth

> Technical & Performance Data

Sizes	4 size mix: 600 x 400 x 60mm, 400 x 400 x 60mm, 400 x 200 x 60mm, 200 x 200 x 60mm
Manufacturing Standard	BS EN 1339:2003
Manufacturing Method	Hydraulically pressed semi-dry concrete
Constituents	Aggregates, sand, admixtures, cement and colour pigments
Permeability	1800 litres / second / hectare
Finish	Standard or Curled (selected colours)
Applications	Domestic and Pedestrian

> Dimensions & Profile

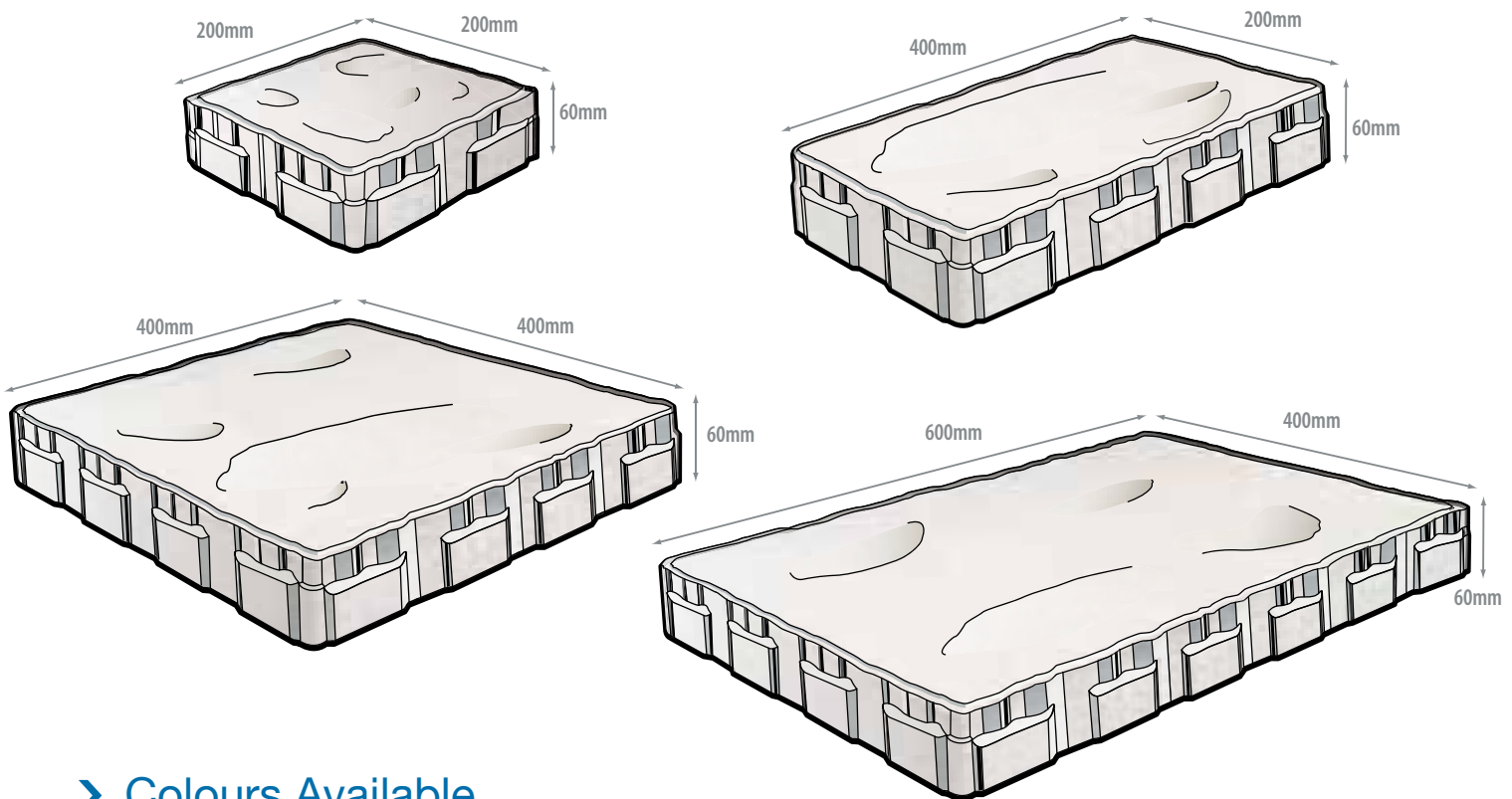

> Colours Available

Block Sizes: 4 size mix: 600 x 400 x 60mm, 400 x 400 x 60mm, 400 x 200 x 60mm, 200 x 200 x 60mm

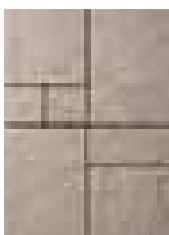

> Stone

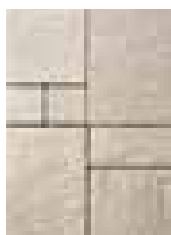

> Silver Granite

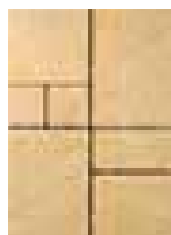

> Yellow

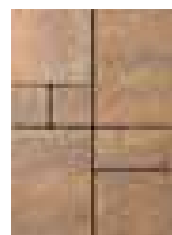

> Curragh Gold

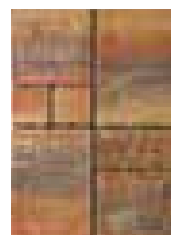

> Rustic



Kilsaran Manufacturing Plant, Piercetown, Dunboyne, Co. Meath

Clima-Pave™

Technical Information

- Design Guidance
- Permeable Paving Aggregates
- Materials for HGV Trafficked Pavements
- Typical Design Diagrams
- Construction & Maintenance Guidelines

Design Guidance

- Clima-Pave™ permeable paving provides a structural pavement suitable for both pedestrian and vehicular traffic depending on design. The water management and permeable functionality of the pavement is largely dependent on the correct specification and design of the pavement to meet the unique requirements of the individual site. The correct specification, testing and installation of aggregates is of paramount importance with any permeable paving system to ensure the finished pavement meets both initial and long term design requirements.

We advise that all permeable pavements require a site-specific design which should be carried out in accordance with BS 7533-13:2009 'Pavements constructed with clay, natural stone or concrete pavers. Part 13 Guide for the design of permeable pavements constructed with concrete paving blocks and flags, natural stone slabs and setts and clay pavers'.

We can provide a design service to customers who require a site specific design to be carried out for their project. In order to carry out this, we require a completed Clima-Pave™ Permeable Paving Design form available to download from our website, from our Sales team or can be requested by emailing technical@kilsaran.ie. This form should be returned via email with the supporting information about the site to enable a design to be carried out.

The information required includes:

- **Drawings of proposed site layout in AutoCad**
- **Full existing and proposed site levels for the pavement**
- **Full site investigation report to establish ground conditions and soaked CBR values of the sub-grade at formation level**
- **Infiltration values from soak-pit testing to BRE 365**
- **Overall drainage design strategy for the site**
- **Planning requirements or conditions for the site relating to paving and drainage (e.g. discharge limits)**
- **Any other pertinent site specific information or client / contractor requirements**

➤ Design Guidance Basics

The below information is provided for guidance purposes only at project conception stage to allow appraisal of a permeable pavement system. Full independent advice should be sought from both the Consulting Engineer and the Contractor prior to the commencement of works. A full site-specific design will always be required in accordance with the above guidelines and BS 7533-13:2009.

The design information below is based on BS 7533-13:2009 which should also be consulted at project appraisal stage.

Types of Permeable Pavement

There are three main types of permeable pavement commonly used on sites:

System A – Full Infiltration: All water from the pavement is infiltrated to the ground

Suitable for sites with good ground conditions, higher CBR values and soils which will readily allow water to dissipate through the ground. These favourable conditions are rarely encountered on larger sites.

System B – Partial Infiltration: Most water infiltrated to ground with excess water piped off

Suitable for sites with medium ground conditions. The soil will infiltrate some of the water in the system. When storm events occur and water builds up in the system due to the soil being at capacity for drainage, perforated pipes are laid in the bottom of the sub-base to deal with the excess, taking it to the surface water drainage system. This is the most commonly used type of permeable pavement.

System C – Fully Tanked System: No water is allowed to infiltrate to ground

This type of system is used where poor sub-grade drainage conditions exist (heavy clays), where the stability of the sub-grade would diminish if extra surface water was introduced, or where ground water levels are within 1 metre of the formation level (system could gain water). In this system the sub-base acts essentially as an attenuation tank, wrapped in an impermeable polythene membrane and all water is piped out.

➤ Selection of Pavement Type

The type of permeable pavement system to be adapted is based primarily on site ground conditions, site suitability and the permeability values of the sub-grade encountered on site from infiltration soak-pit testing. Table 1 gives guidance on the suitability of the three types of permeable pavement system.

Table 1: Guidance on selection of a pavement system

		System A - total infiltration	System B - partial infiltration	System C - no infiltration
Permeability of subgrade defined by coefficient of permeability, <i>k</i> (m/s)	10 ⁻⁶ to 10 ⁻³	✓	✓	✓
	10 ⁻⁸ to 10 ⁻⁶	X	✓	✓
	10 ⁻¹⁰ to 10 ⁻⁸	X	X	✓
Highest recorded water table within 1000mm of formation level		X	X	✓
Pollutants present in subgrade		X	X	✓

➤ Selection of Pavement Sub-Base Thickness

The design of the sub-base for the permeable pavement should take into account the traffic loadings likely to use the pavement. It is essential to take into account any future increase in traffic volume and any HGV traffic which may use the pavement irrespective of how frequent. The correct loading category should be then selected from Table 2 taking into account the above considerations. It should be noted that no layers of the permeable pavement are designed for site traffic to use them and when finished the permeable pavement surface should not be trafficked by site traffic vehicles which are heavier than that for which the pavement was designed. It is advisable to complete paving works after all other work in the vicinity has been completed.

Typical build up details for each traffic category are illustrated on page 20 and 21 for guidance purposes.

Table 2: Loading Categories

1 DOMESTIC PARKING	2 CAR	3 PEDESTRIAN	4 SHOPPING	5 COMMERCIAL	6 HEAVY TRAFFIC
No Large Goods Vehicles	Emergency Large Goods Vehicles only	One Large Goods Vehicles per week	Ten Large Goods Vehicles per week	100 Large Goods Vehicles per week	1000 Large Goods Vehicles per week
Zero standard axles	100 standard axles	0.015msa	0.15msa	1.5msa	15msa
Patio	Car Parking Bays and Aisles	Town/city Pedestrian Street	Retail development delivery access route	Industrial Premises	Main road
Private Drive	Railway Station platform	Nursery Access	School/college access road	Lightly Trafficked Public Road	Distribution Centre
Decorative feature	External Car Showroom	Parking area to residential development	Office block delivery route	Light Industrial development	Bus Station (bus every 5 minutes)
Enclosed Playground	Sports Stadium Pedestrian route	Garden centre external display area	Deliveries to small residential development	Mixed retail/ industrial development	Motorway Truck Stop
Footway with zero vehicle overrun	Footway with occasional overrun	Cemetery Crematorium	Garden centre delivery route	Town Square	Bus Stop
	Private drive/ footway crossover	Hotel Parking	Fire Station Yard	Footway with regular overrun	Roundabout
		Airport Car Park with no bus pickup	Airport Car Park with bus to terminal	Airport landside roads	Bus Lane
		Sports Centre	Sports Stadium access route/ forecourt		

msa = millions of standard 8,000 kg axles

➤ Sub-Base Thickness For Water Storage

The sub base depth must also take into consideration the water storage requirements for the site. The depth of sub-base may have to be adjusted to allow for increased site specific water storage. Further guidance on hydraulic factors can be found in BS 7533-13:2009 section 5.4.

➤ Adjustment To Pavement Design For Low CBR Sub-Grade

In the case of CBR values below 5%, either ground improvement work will be required for the site, or the thickness of the coarse graded aggregate sub-base will have to be adjusted in accordance with 5.6.3 and table 9 of BS 7533-13:2009

Permeable Paving Aggregates

➤ All materials used as permeable paving aggregate must comply to the grading and physical requirements below, as well as the general requirements of BS EN 12620 and BS EN 13242. Sub-base laying course materials should be clean, sound, non-friable and sound crushed rock material. Rounded gravel materials are not recommended for sub-base layers. The jointing material may be either clean crushed material or clean gravel material. The materials should be tested to confirm that it meets the requirements below.

The contractor shall also ensure that on-going deliveries to site are checked frequently for grading, shape and inspected to ensure cleanliness.

During installation on site, great care and attention must be paid to ensure that the aggregates are kept free of contamination and deleterious matter. Construction traffic cannot be allowed to traverse the layers of permeable paving aggregates during installation.

4/40mm Coarse Graded Permeable Paving Aggregate	
Sieve Size (mm)	Percentage Passing
80	100
63	98-100
40	90-99
31,5	-
20	25-70
10	-
4	0-15
2	0-5

4/20mm Coarse Graded Permeable Paving Aggregate	
Sieve Size (mm)	Percentage Passing
40	100
31,5	98-100
20	90-99
10	25-70
4	0-15
2	0-5

2/6.3mm Laying Course Paving Aggregate	
Sieve Size (mm)	Percentage Passing
14	100
10	98-100
6.3	80-99
2	0-20
1	0-5

3mm Jointing Grit	
Sieve Size (mm)	Percentage Passing
40	100
8	100
6.3	95-100
4	85-99
2	15-35
1	0-10
0.063	0.0-1.5

Property	Category to BS EN 13242 or BS EN 12620
Grading	4/20 (preferred) or 4/40 as per table above
Fines Content	F4
Shape	Fl20
Resistance to Fragmentation	LA30
Water Absorption to BS EN 1097-6:2000	WA2
For water absorption > 2% Magnesium Sulfate Soundness	MS18
Resistance to Wear	MDE20
Acid Soluble Sulfate Content	AS0.2
Total Sulfur	≤1% by mass
Recycled Aggregates	Seek guidance from Kilsaran Technical Department

Materials for HGV Trafficked Areas

➤ For loading category 3 and above as detailed in Table 2 page 17, these pavement types are designed to accommodate HGV traffic either on an occasional or more frequent basis. The pavement structure therefore requires a 'stiffening layer' to accommodate the HGV traffic which exerts significantly increased loading on the pavement. This stiffening layer can be either a hydraulically-bound coarse graded aggregate (porous no fines concrete) as detailed below and shown on the section details on pages 20 and 21 or alternatively a 80mm thick layer of DBM macadam as detailed below.

➤ DBM Macadam Material

The DBM material should be an AC 32 Dense Base complying with the requirements of BS EN 13108-1 and should be supplied and installed to meet the requirements of BS 594987:2010. The DBM should be punctured after installation at 750mm centres with 100mm diameter holes. The holes should be fully filled and compacted with the appropriate coarse graded permeable paving aggregate as used in the layer underneath.

➤ Hydraulically-Bound Coarse Graded Aggregate (Porous No Fines Concrete)

Porous concrete provides a stiffening transfer layer in concrete block permeable pavements which are to receive heavier traffic loads. The lack of sand (fines) in the mixture allows the material to act as a transfer drainage layer, whereby the open-graded matrix of the material allows for 20%-30% voids within the compacted volume of the material. Special measures are to be taken in the production, installation and curing of this material. Kilsaran can provide information and guidance on this upon request.









Product Standard	BS EN 14227-1
Material Composition	Hydraulically Bound Coarse Graded Aggregate is a mixture of a coarse aggregate (usually 20mm nominal size), cement and water.
Typical Compressive Strength	Class C5/6 in accordance with IS EN 14227-1, Table 2 Line 4. Other strength classes available upon request from supplier.

Typical Design Diagrams

Below are typical build-up details for permeable pavement systems based on BS 7533-13:2009. These diagrams are based on ideal site conditions for drainage and CBR values of 5% or greater. The diagrams are for project appraisal purposes only and in all cases a site specific design in accordance with BS 7533-13:2009 will be required.

Key:

	2 / 6.3mm Laying Course
	Hydraulically-Bound Coarse Graded Aggregate or 80mm of DBM Macadam
	4 / 20mm Coarse Graded Aggregate and /or 4/40mm Coarse Graded Aggregate
	Capping Material
	Approved Geotextile
	Approved Impermeable Membrane

System A & B (Infiltrating & Partial Infiltration Systems)

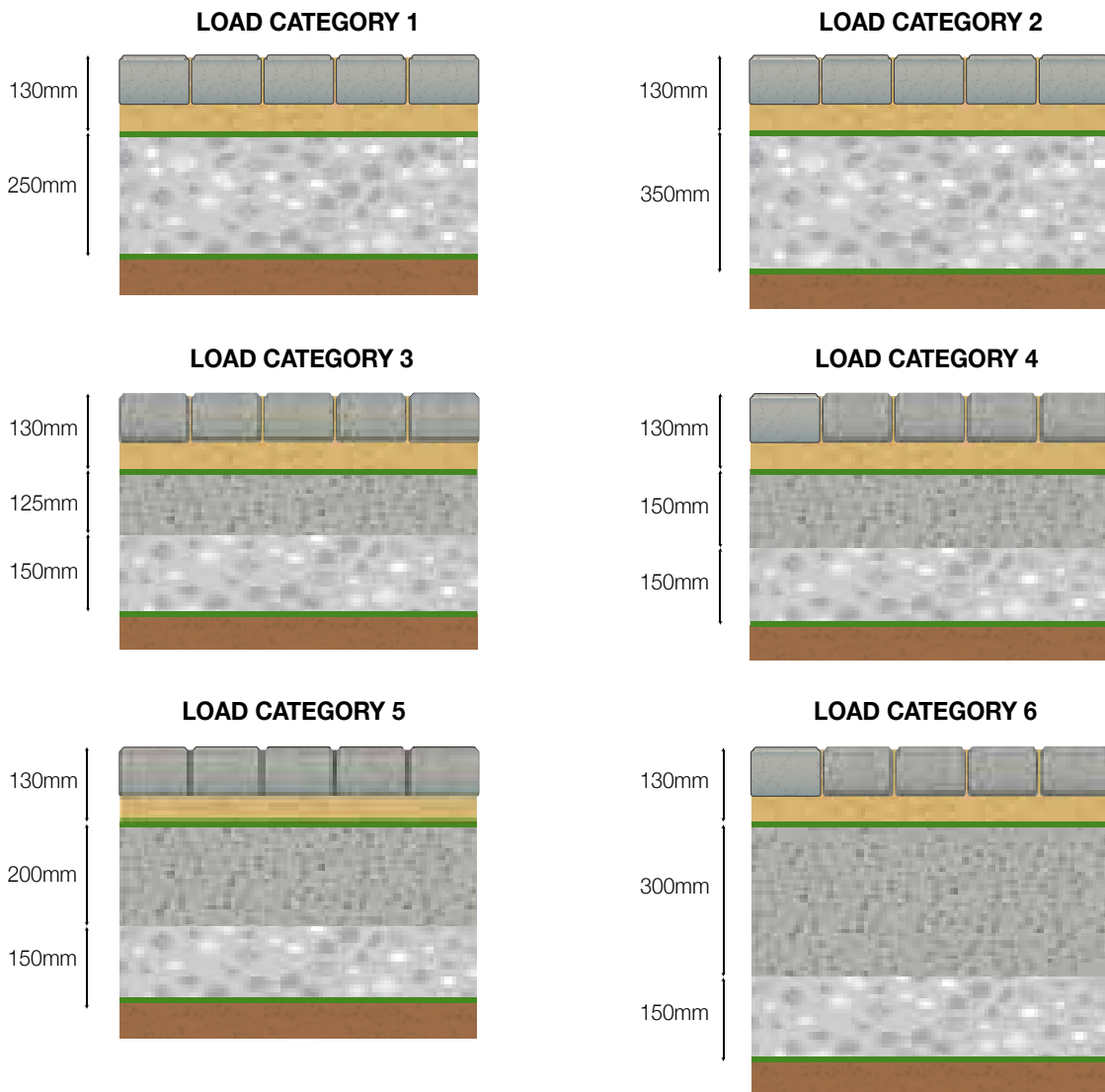

Alternative build up / materials may be used depending on project specific details.

For load categories 3-6 the hydraulically-bound coarse graded aggregate (porous no fines concrete) layer may be replaced with 80mm depth of DBM Macadam to act as a stiffening layer. The macadam layer should be punctured at 750mm centres on grid. Further details on the DBM macadam layer are given on page 19.

Where the depth of aggregate sub-base is in excess of 350mm for the given loading category, it may be possible to reduce the depth of aggregate required and provide a more cost effective design with the use of an appropriate and approved geo-grid. This can be appraised at design stage.

System C (Fully Tanked/Bunded)

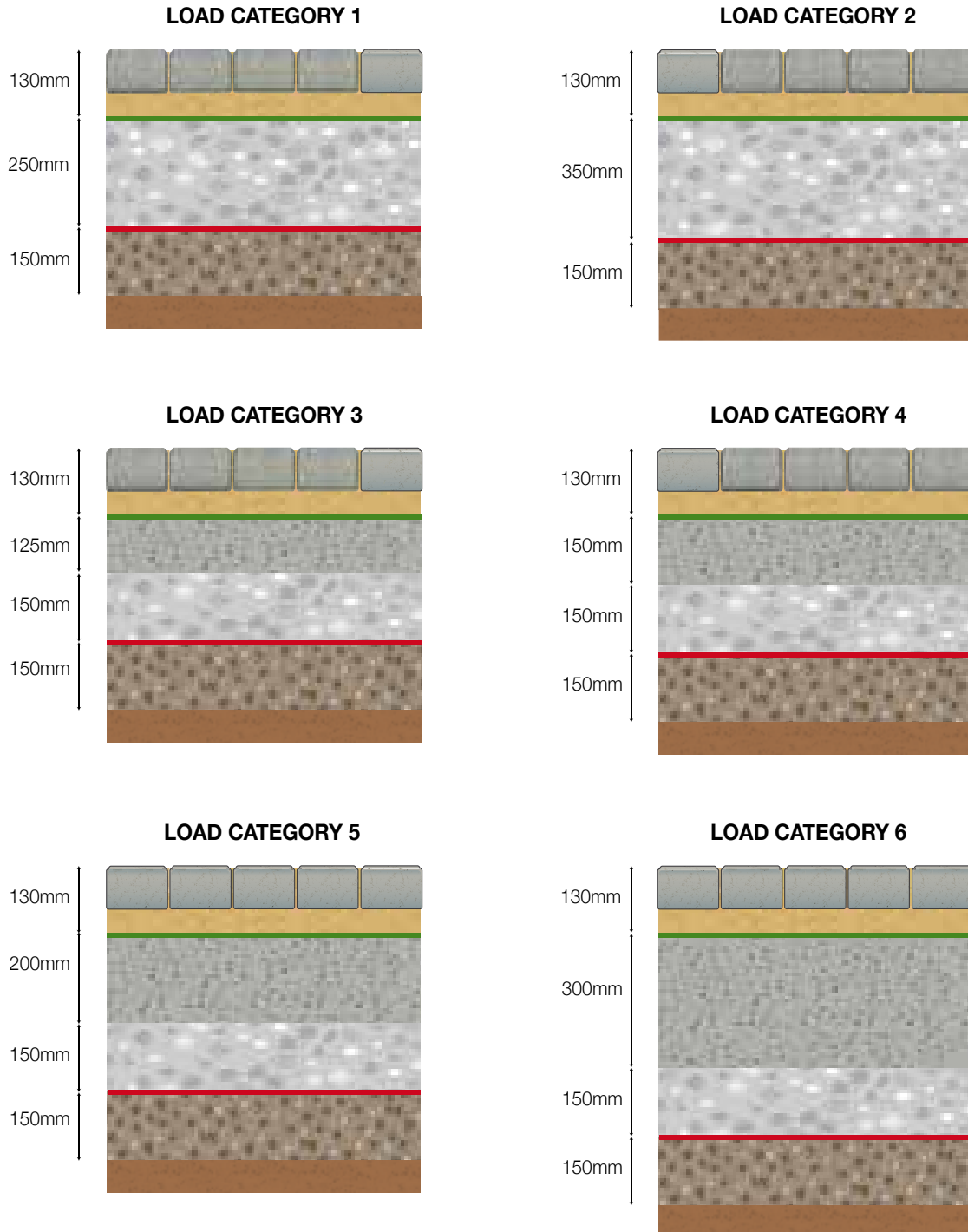

In the case of System C (fully tanked permeable pavements) there is always a requirement for 150mm depth of capping to be used beneath the impermeable membrane as shown above. The capping material should be approved by the Engineer and should comply with either the NRA Specification for Roadworks Series 600 or the Specification for Highway Works Series 600. The material should be tested before and during supply for full compliance, and should be compacted in accordance with the series 600 requirements. The capping layer should be blinded immediately before laying the impermeable membrane to prevent puncturing the membrane.

The requirement for using capping material may be eliminated by carrying out a design using an appropriate geo-grid which would negate the requirement for both the capping material and may also reduce the total depth of sub-base stone required.

➤ Sloping Sites

On sloping sites water will naturally collect at the lowest point of the pavement. If sharp falls are allowed on site this will reduce the effective water storage capacity of the sub-base aggregate. In order to minimise this effect, gradients should be at a maximum 1 in 20 and preferably 1 in 30 or better.

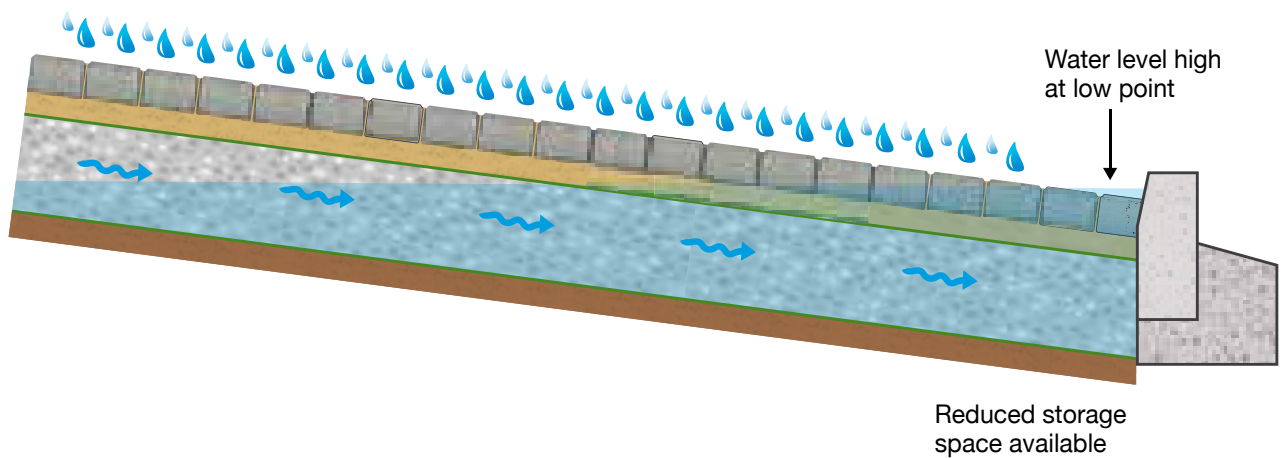

Where sloping sites are unavoidable due to site layout, it will be necessary to reduce any sharp falls to maintain the water attenuation capacity of the system. This can be achieved by creating 'dams' in the sub-base of the pavement which will 'step' the pavement sub-base and reduce the overall falls. On extreme slopes, the pavement can be terraced with a step down and a dam between the two levels to restrict water flow.

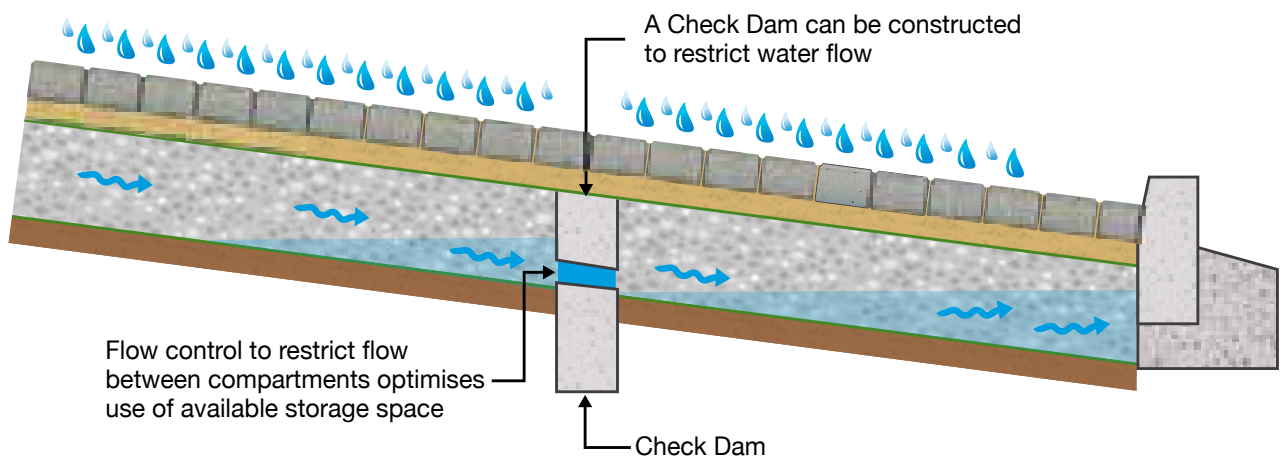

Construction & Maintenance Guidelines

➤ Construction

To ensure correct performance and durability of a permeable pavement, a fully detailed design should be carried out in accordance with BS 7533-13:2009 taking into account all site specific requirements for the project. Construction should be carried out strictly in accordance with BS 7533-13:2009 and BS 7533-3. All materials to be used shall be tested for full compliance to the above standard both before supply and during construction. It is also advised not to use any of the layers of permeable pavement construction for site traffic unless the build-up has been specifically designed to accommodate this. Additionally site equipment such as tele-handlers and forklifts should not be used on the paving surface after construction has been completed unless the pavement has been designed to accommodate this.

➤ Maintenance

Permeable pavements should not be contaminated with soft landscaping materials, soil, detritus or general dirt as this may wash into the pavement. Also the pavement should not be trafficked by construction traffic or unsuitably heavy vehicles above that for which the pavement was designed.

To keep any growths or weeds to a minimum it is advised that the installed permeable paving be sealed with an appropriate sealer. Where the paved area is beneath overhanging trees or in a very damp area, an annual treatment of an environmentally friendly weed killer can be applied. Note the weed killer should be applied as directed by the supplier and only in very dry weather where rain is not expected, active weed killer could be washed into the sub-system otherwise. The manufacturer's instructions for all treatment products should be followed in detail.

The pavement should be inspected on a routine basis and carefully swept as required using a mechanical sweeper or by hand for smaller areas. The sweeping action may remove some of the jointing grit from the surface, the joints must be topped up after sweeping if required.

Should silting or blocking of the joints occur after a period of years, the use of a suitable jet wash and suction sweeper should be used to remove the defective material. It is likely that the jetting of the pavement will remove some grit. This grit should be replaced as required.

As with conventional block pavements, depressions, rutting and cracked or broken blocks which may be a structural concern or a hazard to users should be remedied as soon as possible. All joints must be maintained full at all times.

Permeable pavements will drain relatively quickly compared with other types of surfacing, and are not as liable to freezing over of standing water, hoar frosts may occur which can cause surface slip on any material. The use of de-icing salts on permeable pavements, as with any other concrete surface, should be kept to a minimum as the chlorides in the salt will penetrate the concrete and excessive use will damage the surface. Any de-icing material applied should not cause blockage or clogging of the permeable pavement joints (if blockage occurs in localised areas this will need to be removed by suction sweeper and joints topped up with appropriate jointing grit). It should also be considered that any de-icing material used will drain into either the sub-grade or the drainage system through the permeable pavement. Care should be taken to ensure no contamination of water courses or drainage systems. De-icing materials should be applied to the paving surface before ice or snow covers the surface to prevent damage.

This Brochure

This brochure was printed in December 2011 and the information within it supersedes all previous brochures. We have taken every reasonable precaution to ensure that all details contained in the brochure are accurate. We are an innovative company and we seek to develop our product ranges and product lines on an on-going basis. We recommend that you check online or by calling us to ensure that you have the most up-to-date product information to hand.

Our Paving Products

When our product is delivered and before it is laid, the customer should satisfy themselves that the product is free from defects or damage. Any product failing to meet the product specification will be replaced as per our product promise. Our product promise relates strictly to the product only. Kilsaran cannot accept liability for replacement installation costs and/or delays incurred as a result of product that is defective or damaged which is laid. Any defects must be notified to Kilsaran immediately.

Small scuffs or scratches on the surface of our paving products may arise during transportation, handling of the product on site or compaction. These scratches are quite normal and will disappear over time. They do not affect the integrity of the product in any way.

Efflorescence

Efflorescence may occur as a naturally occurring phenomenon when temporary white stains may appear on the paving product surface. This is inherent in high quality concrete products produced with natural materials, this is not a product defect. Over time, these stains are gradually washed away by rain and weathering. Kilsaran cannot accept responsibility for these natural occurrences.

Colour Illustrations

Through the use of the most modern photographic techniques available we endeavour to ensure that the colour illustrations of our paving products in this brochure are as accurate as possible. We do recommend that any final decision is based upon viewing a sample of the product. These samples can be provided by our regional Sales & Account Managers, your laying contractor or at our Display Showrooms in Dunboyne, County Meath, Ireland.

Colours and Blending

Kilsaran uses high-quality photo stable iron oxide pigments to create the various colours in the paving products range. As with all concrete products, our paving products may be subject to slight colour variation due to the natural variation in raw materials used and from weathering over time. These are natural occurrences inherent in all concrete products, Kilsaran cannot accept responsibility for these natural occurrences.

When laying, in order to achieve an even blend of colour, it is essential to work equally from a minimum of 3 - 6 packs, laying evenly from each. It is essential to measure the area to be paved accurately allowing for waste. The full quantity of required product should be advised to Kilsaran so that we may deliver as one batch. Additional material subsequently ordered may delay the completion of your project and may be from a separate production batch and there may be a shading difference.

Returned Products

Kilsaran does not accept returns on any materials.

Commitment to Customer Satisfaction

We strive to provide the best products in the market backed up by superior customer service. If our products or service do not meet your expectations please contact us.

Special Orders

The colour swatches displayed in this brochure best reflect our most popular colours within specific product ranges at the time of going to print. It may be possible to produce these products in other colours not displayed on the relevant swatch depending on the order volume. Kilsaran reserves the right to refuse to manufacture products in specific colours. Special colours may be subject to greater lead time than standard stock colours.

get in touch

Kilsaran ROI

Piercetown
Dunboyne
Co. Meath

T: 01 802 6300
E: technical@kilsaran.ie
www.kilsaran.ie

Kilsaran UK

Unit 16 Premier Park
Acheson Way
Trafford Park
Manchester M17 1GA

T: 0161 872 8899
E: technical@kilsaran.ie
www.kilsarangroup.co.uk



Mixed Sources

Product group from well-managed
forests, and recycled wood or fibre
www.fsc.org Cert no. TT-COC-002507
© 1996 Forest Stewardship Council



Get in touch:

ROI: Call 01 8026300

www.kilsaran.ie

UK: Call 0161 872 8899

www.kilsarangroup.co.uk

